

NORD

HTechnology

EcoBoiler 160

ASSEMBLY
AND
OPERATION INSTRUCTIONS

Content

- 1 Preface 2**
- 2 Functional description 3**
- 3 Notes for the user 4**
 - 3.1 Energy savings 4
 - 3.2 Stand-by energy consumption 4
- 4 Technical data 4**
- 5 Intended use 6**
- 6 Wall mounting..... 6**
- 7 Note on water quality 7**
- 8 Domestic hot water side connection (pressure-resistant) 7**
- 9 Electrical installation 9**
- 10 Connection with NORD Power Genius 3000.....10**
- 11 Operation.....11**
 - 11.1 Hot water pouring rates 13
- 12 Pipeline network to the tapping points13**
- 13 Potential equalisation14**
- 14 First commissioning.....14**
 - 14.1 Procedure for commissioning the water heater 14
- 15 Decommissioning, draining14**
- 16 Control, maintenance, care15**
- 17 Most common dysfunctions and their causes16**
- 18 Warranty, guarantee and product liability.....16**
 - 18.1 Warranty..... 16
 - 18.2 Extended voluntary warranty..... 17
 - 18.3 Reasons for exclusion..... 17
 - 18.4 Product liability..... 18
- 19 Notes on transport and storage.....18**
- 20 Disposal.....19**

1 Preface

Dear customer!

You have chosen a NORD EcoBoiler 160 suspended hot water storage tank from our company.

Thank you for your trust!

In this manual, we will focus on the suspended hot water storage tank, which was built according to the rules of technology and complies with the applicable regulations. The environmentally friendly CFC-free insulation foam ensures low standby energy consumption.

Installation and initial commissioning may only be carried out by a licensed installation company in accordance with these instructions.

This brochure contains all the basic instructions for correct installation and operation. Nevertheless, it is advisable to have your authorised installer explain the function of the appliance and demonstrate its operation. Of course, our customer service and sales department will also be happy to advise you.

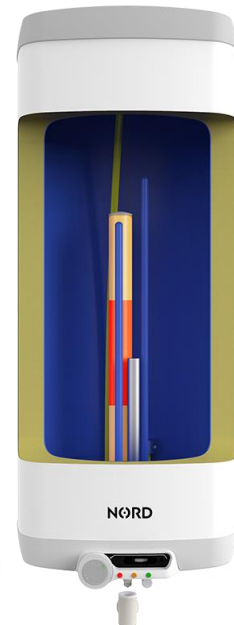

The product must not be operated:

- a) by persons with limited physical, mental or spiritual abilities, or
- b) by persons lacking sufficient experience and knowledge, unless they have been supervised or properly trained by an authorised person.

Please read all the information contained in these instructions carefully, keep them in a safe place and pass them on to any subsequent owner.

The manufacturer reserves the right to make technical modifications to this product. The product is intended for permanent contact with drinking water.

We recommend using the product indoors at air temperatures from +2 °C to +45 °C and a relative humidity of max. 80 %.

Enjoy your NORD EcoBoiler 160!

Meaning of the pictograms used in the operating instructions:



Important information for the user of the hot water cylinder.



Manufacturer's recommendation, compliance with which will guarantee you, problem-free operation and a long service life for the product.



Important note that must be observed.

2 Functional description

This water heater with patented technology is designed for the so-called storage heating of domestic hot water by means of electric current. The patented design and control allow easy and efficient use of renewable energy, such as that provided by photovoltaic (PV) systems.

The water is heated by an electric heating element mounted in the enamelled, thermally insulated storage tank. Due to the special design of the patented heating element, the heating takes place in layers from top to bottom. Each zone of the heating element is controlled by a thermostat during heating. The top zone (24h comfort zone, approx. 80 litres) allows infinitely variable adjustment of the desired temperature (in the range approx. from 5 °C to 80 °C) and it is ready for use 24 hours a day. The heating elements of the PV zone are factory-set to a fixed temperature of approx. 60 °C and are activated via a switch contact. This switch contact can be controlled e.g., via a time switch or an energy management system (NORD Power Genius 3000) – you can find more about this option in chapter 10. *Connection with NORD Power Genius 3000*. In conjunction with the storage capacity in the 24h comfort zone, the reheating of the storage tank is mainly limited to those times that have a particularly high proportion of renewable energy or favourable tariffs. After reaching the desired temperature in the respective zones, heating is automatically interrupted.

The hot water accumulated in the storage tank is used for consumption. The tank is constantly pressurised with water from the water supply pipe. When the hot water valve of the mixer tap is open, the water flows out of the water heater due to the pressure of the cold water from the water pipe. The hot water flows out of the upper part, the incoming water remains in the lower part of the hot water tank.

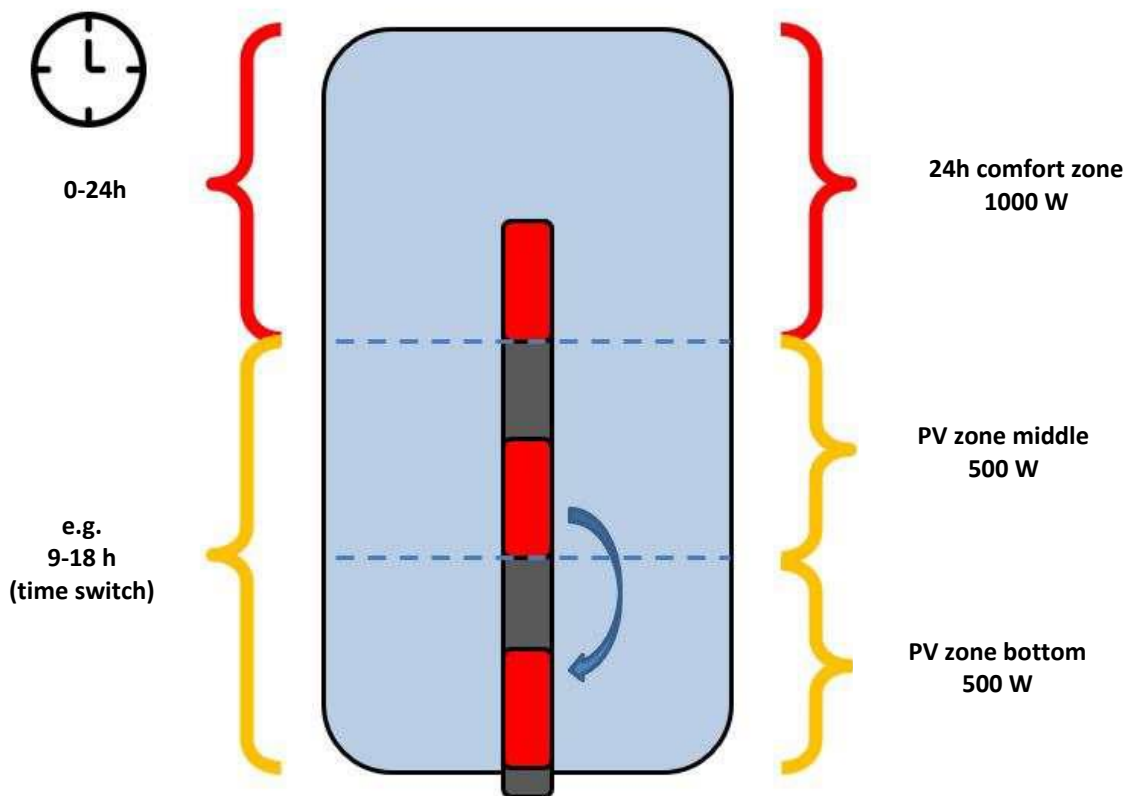

3 Notes for the user

3.1 Energy savings



The storage tank has thermal insulation made of high-quality, CFC-free polyurethane foam. Please set the temperature on the thermostat of the water heater only as high as is necessary for your household operation. In this way, you not only reduce electricity consumption, but also reduce the amount of limescale deposits on the tank walls and on the immersion tube of the electric heating element.

3.2 Stand-by energy consumption



Even if no hot water is drawn from the tank, there is still some heat loss, albeit minor. This heat loss is measured for 24 hours at a temperature of 65 °C in the water heater and at 20 °C ambient temperature. The resulting value is given in the unit [kWh/24 h] and represents the amount of energy required to maintain the set temperature.

4 Technical data

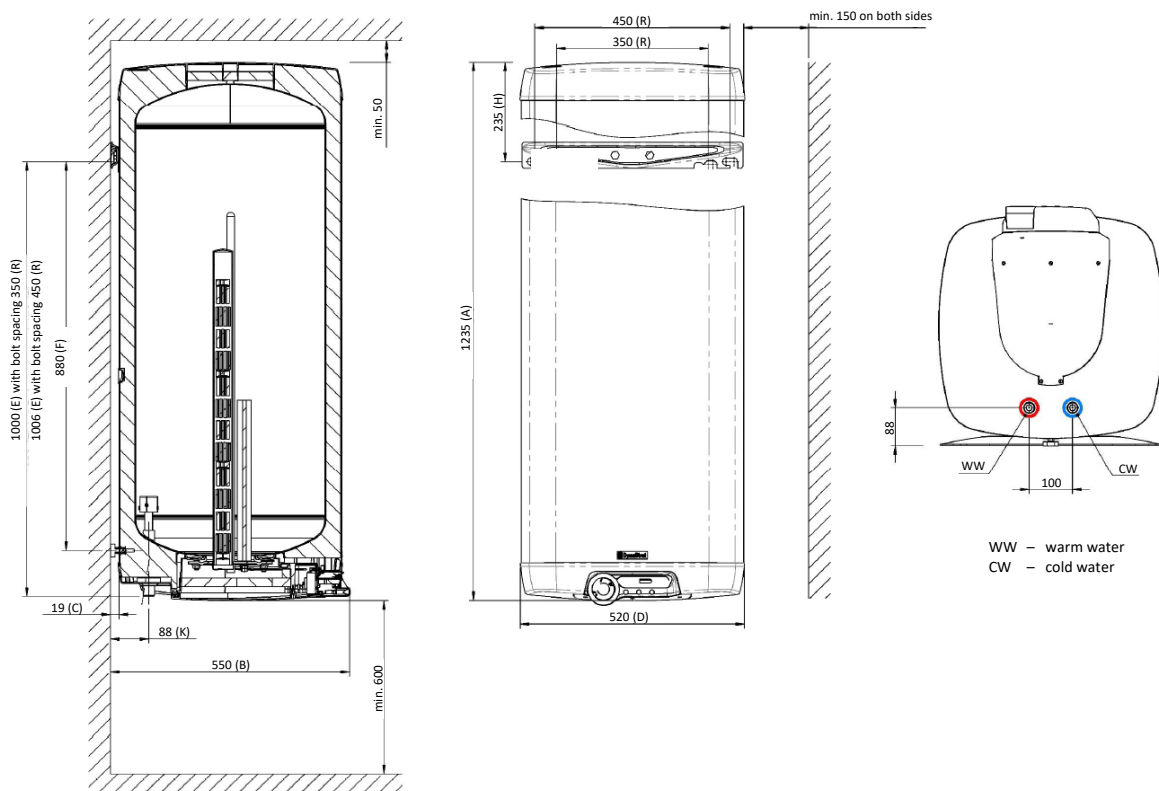

| Technical data | |
|---|--|
| Storage material | Steel, enamelled, with protective anode |
| Storage capacity [liters] | 152 |
| Dimensions (H/W/D) [mm] | ~1235/520/550 |
| Other dimensions [mm] | A: 1235 / B: 550 / C: 19 / D: 520 / F: 880 / H: 235 / K: 88 |
| Connection dimensions for connection set [mm] | Distance of suspension bolts R: 350 – Dimension E: 1000 Distance of suspension bolts R: 450 – Dimension E: 1006 |
| Connection dimension | 3/4" male thread |
| Max. perm. operating pressure [bar] | 6 |
| Cold water test pressure [bar] | 9 |
| Max. operating temperature [°C] | 90 |
| Weight (empty) [kg] | 51 |
| Storage tank insulation | Pressure-foamed PU rigid foam, CFC-free |
| Outer jacket | Sheet steel, white powder-coated |
| Load profile | M |
| Energy label incl. PV | A (1.5 kWp, 1.2 kWp), B (0.9 kWp, 0.6 kWp) |

| Installation | |
|--------------------------|---|
| Inspection flange | Diameter inside 150 mm |
| Electric heating element | Patented electric heating element, 3-stage 24h comfort zone top: 1000 W PV zone middle and bottom: 500 W each installed in an envelope tube welded to the flange cover. Incl. thermostatic control with shift loading (comfort zone adjustable up to max. 80 °C) and all-pole safety temperature limiter (95 °C) as well as integrated control relay (230V, 1~) for the PV zone. |
| Operating elements | Operation via panel on the front: Stepless temperature control of the 24h comfort zone with energy-saving setting and frost-protection setting. |
| Display elements | Different coloured signal lamps for all three heating zones, thermometer (analogue). |

| Connections | |
|------------------------|---|
| Cold water | DN20 - 3/4" AG sealing on thread |
| Hot water | DN20 - 3/4" AG sealing on thread |
| Electrical | Terminal area for power supply 230 V, 1~, max. 2 kW Clamping range for free PV layer loading 230 V, 1~, (internal relay) |
| Potential equalisation | Via connection cable |

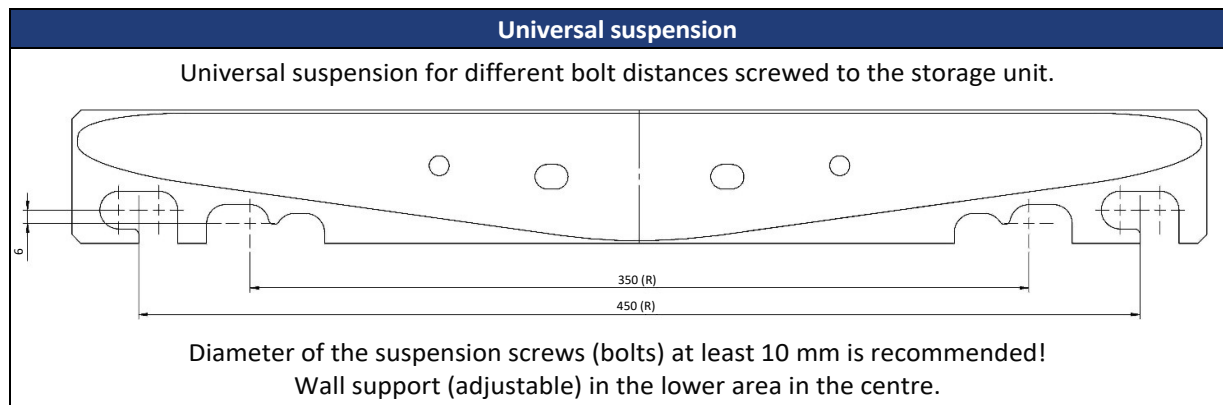

| Available accessories |
|--|
| Suspended EcoBoiler 160 connection set incl. safety group Art. No. O-525-11b |

5 Intended use



The appliance is only suitable for hot water production inside closed rooms and may only be installed by authorised specialists in accordance with applicable international and related local laws, codes and regulations. The boiler may only be used in accordance with the conditions specified on the rating plate. In addition to the legally recognised national regulations and standards, the connection conditions of the local electricity and water works as well as the installation and operating instructions must also be observed. The latest valid planning documents must be observed.

6 Wall mounting



The room in which the appliance is operated must be frost-free. Before installation, the load-bearing capacity of the wall and the material it is made of must be checked with regard to the weight of the water-filled water heater. Depending on the wall material, the appropriate anchoring must be selected. If in doubt about the load-bearing capacity of the walls, consult a building specialist about the suspension. The minimum diameter of the water heater's suspension screws should be 12 mm. When installing the anchor bolts, proceed according to the anchor manufacturer's instructions.

According to the dimensions shown in the table above, place the suspension screws at a distance of preferably 450 mm. Vertical alignment is achieved after loosening the fixing screws by slightly twisting the suspension. Check that the suspension screws on the water heater are tight and hang the water heater. You can use a locking support in the lower part of the unit to ensure that it hangs parallel to the wall!



The unit must be installed in a place that allows maintenance of the water heater and all associated fittings, including their removal. This means that all structural arrangements that prevent problem-free installation must be removed by the end customer.

A free space of 800 mm from the lower edge of the water heater must be left under the water heater. When installing the water heater close under the ceiling, the distance from the ceiling must be at least 50 mm. When setting up, installing and operating the water heater in unusual locations (e.g.: attics, living areas with water-sensitive floors, above electrical or IT centres, or above or in rooms in which considerable water damage can occur due to a burst pipe, etc.), any water leakage must be taken into account and a device for

collecting the leaking water with an appropriate drain must be provided in order to prevent secondary or consequential damage.

When installing the unit, the planning documents, dimensional sketches and any enclosed information signs must be observed.

Distances to combustion systems can be found in the manufacturer's documentation as well as in the corresponding regulations. If a water heater is fitted with modifications (cladding), installed in narrow, small rooms and such, it is essential to ensure that the connection strip of the appliance (water connections, electrical connection compartment or heating installation) remains freely accessible and that no heat build-up occurs.

7 Note on water quality



If the water has a high lime content, we recommend connecting a common descaling device upstream of the appliance or setting the thermostat to a maximum operating temperature of 60 °C (setting in the "OPTIMUM" position). For proper operation, it is essential to use drinking water of appropriate quality. To prevent possible sedimentation, we recommend installing a water filter upstream of the appliance. Basically, depending on the degree of hardness of the water (even below 15°dH), operating temperature and other influences, a certain amount of limescale will occur, which should be removed at appropriate intervals.

Other corrosion-relevant factors are flow velocities in the heat exchanger, contamination of the water, soiling or deposit formation in the heat exchanger as well as mixed installations.

If particularly aggressive water is present, which requires special solutions on the installation side, the possible necessity of special designs of the storage tanks should also be checked (enquiries should be made to our representatives or to the manufacturer). In the event of damage, non-observance of this regulation constitutes improper use and means the exclusion of all claims against our representatives or manufacturer for whatever legal reason.

8 Domestic hot water side connection (pressure-resistant)

For proper operation of the water heater, drinking water quality in accordance with applicable international and related local laws, codes and regulations is necessary.

All water heaters that have the designation nominal pressure 6 bar on their rating plate can be connected pressure-tight with the corresponding line pressure. If the line pressure is higher or if pressure fluctuations must be expected, it is mandatory to install a pressure reducing valve in the cold water supply line. If unsuitable or non-functional storage tank connection fittings are used and the specified operating pressure is exceeded, any (possible) guarantee, warranty and/or product liability for our wall-mounted storage tank will be rejected. Only pressure-resistant fittings may be used.

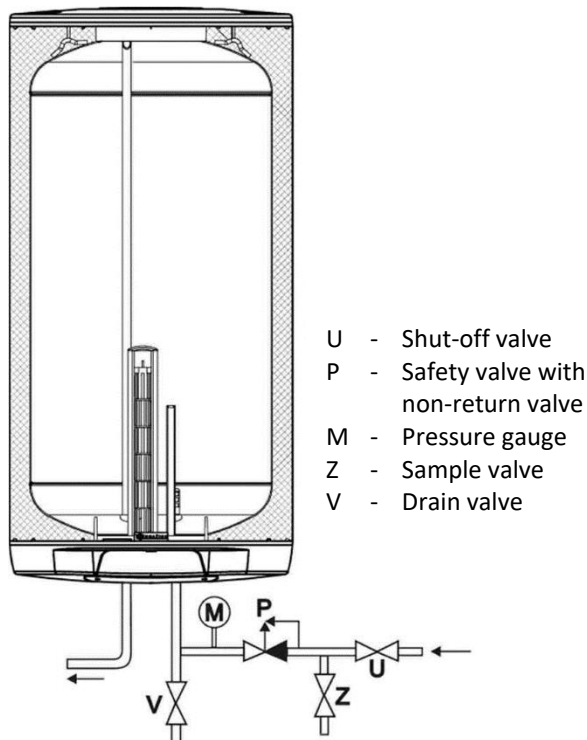

The component-tested safety devices must be installed in the cold water pipe according to the connection diagram below. A type-tested safety group in accordance with applicable international and related local laws, codes and regulations for closed water heaters must be installed in the water connection of the cold water pipe (cold water inlet). The water connection may only be made via a tested membrane safety valve or a membrane safety valve combination connection fitting (no piston valve) for pressure-resistant storage tanks! A safety valve combination consists of a shut-off, test, return, drain and safety valve with expansion water flow and is installed between the cold water supply line and the cold water inlet of the storage tank in the sequence shown on the left side of this page (schematic representation).

To ensure proper functioning of the connection fitting, it may only be installed in frost-protected rooms. The drain of the safety valve must be open and observable and the drain pipe from the drip catcher (expansion water funnel) must be led into the waste water channel, which must be formed by means of a suitable siphon. This way, neither frost nor blockage by dirt or the like can cause a malfunction. No shut-off valve or other restriction may be installed between the safety valve and the cold water inlet of the storage tank. The safety valve must be set to a set pressure that is lower than the nominal pressure of the storage tank. Before final connection of the storage tank, the cold water supply line must be flushed.

After the water has been connected and the storage tank has been filled without any bubbles, the function of the connection fitting must be checked. When lifting or turning (venting) the safety valve test knob, the water must be able to flow off through the expansion water drain funnel without any problems and without any accumulation. To check the return valve, the shut-off valve is closed - no water may flow out of the open test valve. The test of the safety valve must be carried out in accordance with applicable international and related local laws, codes and regulations. The hot water tank is operated by the hot water valve of the service tap (mixer tap). The storage tank is therefore permanently under line pressure. To protect the inner boiler from overpressure during heating, the expansion water that occurs is diverted through the safety valve. In the event of a drop in line pressure, the return valve prevents the hot water from flowing back into the cold water line network and thus protects the boiler from heating up without water. The shut-off valve allows the storage tank to be separated from the cold water pipe network on the water side and thus also in terms of pressure and, if necessary, to be drained by means of the drain valve.

We recommend the use of the matching suspended EcoBoiler 160 connection set incl. safety group Art. No. O-525-11b.

9 Electrical installation



The following requirements must be observed for the electrical installation:

- The diagram of the electrical connection is enclosed with the water heater on the electrical installation housing.
- The connection to the electrical network must be made in accordance with the applicable national regulations and standards, the corresponding connection conditions of the local electricity and water works, as well as the specifications of the installation and operating instructions, and may only be carried out by a licensed electrician.
- A residual current circuit breaker with the necessary tripping current for the system must be connected upstream of the circuit. The unit may only be connected to permanently laid cables. The unit must be preceded by an all-pole disconnecting device with a contact gap of at least 3 mm. Contact gap must be connected upstream of the unit. This requirement is fulfilled e.g., by a circuit breaker.
- When installing in bathrooms, laundry rooms, washrooms and showers, proceed in accordance with applicable international and related local laws, codes and regulations.
- The electrical parts of the water heater have protection class IP 44.
- Observe the protection regulations against electric shock in accordance with applicable international and related local laws, codes and regulations.

The water heater has two electrical connections:

1. Connection heating element
 - This connection supplies the heating element with electric current.
 - The connection must be made with 230 V, 1~, the power is max. 2 kW (2000 W).
2. PV control
 - This connection enables the heating elements in the PV area via an internal relay.
 - The connection must be made with 230 V, 1~, the power is max. 2 W.

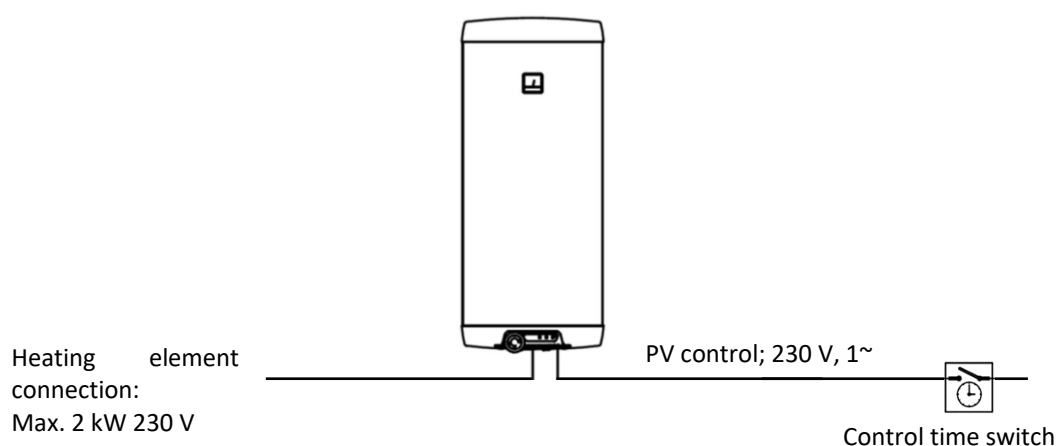

Remove the partition in the electrical installation cover that corresponds to the diameter of the supply cable, i.e., $\varnothing 8$ or $\varnothing 10$.

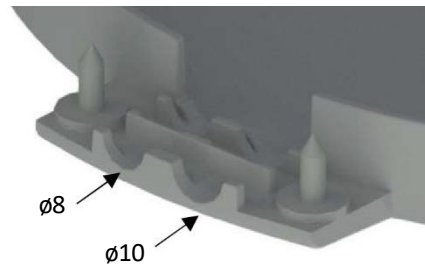
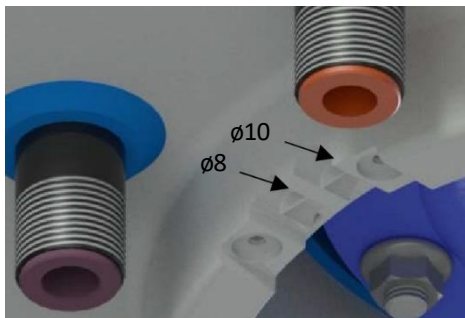

The connection must be made according to the connection diagram. The connection made at the factory must not be changed!

R1 = 1000 W
R2 = 500 W
R3 = 500 W

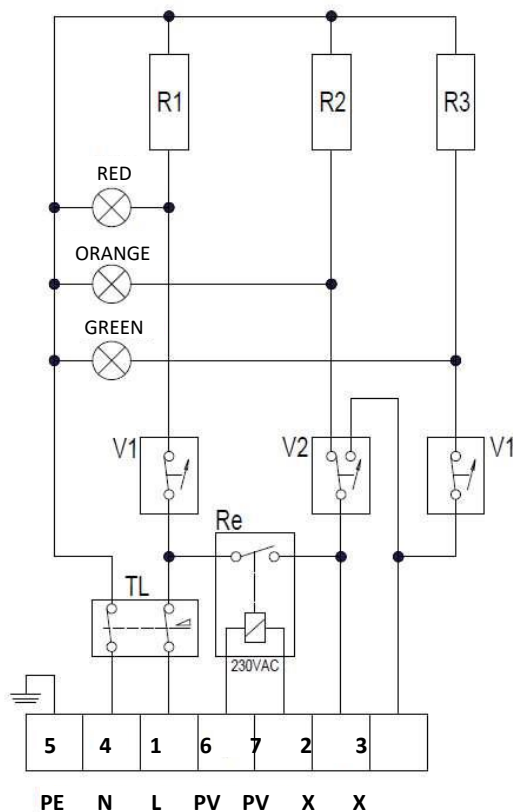

Terminals:

- 1, 4, 5 ... Heating elements
- 6, 7 PV control
- 2, 3 Service (no connection)

Attention:

The terminal labelling 1-7 of the terminal strip of the water heater is consecutive and does not correspond to the arrangement in the E-connection diagram!

Actual connection situation:

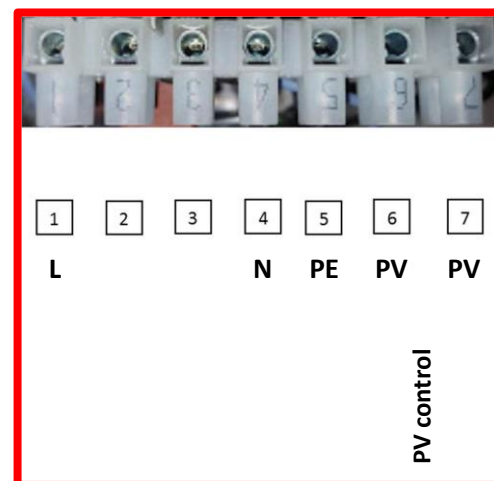

10 Connection with NORD Power Genius 3000

To maximise efficiency of your system please see the connection and configuration of green energy manager NORD Power Genius 3000 with the NORD EcoBoiler 160 water heater for the gradual heating of the PV zone with the surplus from the photovoltaic system, which is described in relevant manual of NORD Power Genius 3000 that can be found on the website of your distributor.

11 Operation

After connecting the water heater to the mains, the heating elements heat the water. The heating elements are switched on and off by a thermostat. After the set temperature has been reached, the thermostat interrupts the circuit of the respective heating element and thus the water heating.

The control lamp indicates which heating element is in operation (control lamp lights up) or out of operation (control lamp goes out).

- RED: Heating element top (24h comfort zone)
- ORANGE: Heating element in the middle (PV zone middle)
- GREEN: Heating element bottom (PV zone bottom)



The temperature of the 24h comfort zone can be adjusted with the rotary knob.

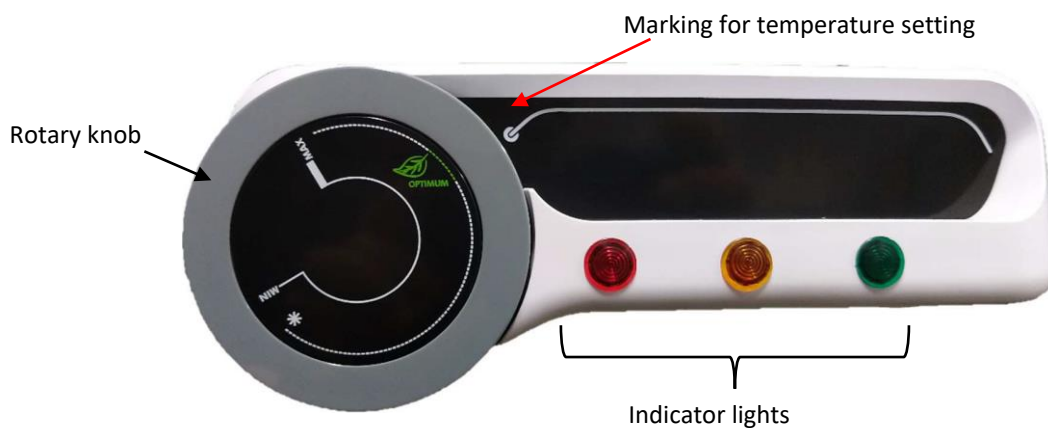

Note: In conjunction with a PV system, we recommend the "PV" setting. In this setting, the comfort zone is heated up to approx. 45 °C if required and reheating outside the PV switching times is prevented due to natural cooling. In this setting, the maximum storage tank temperature is determined via the PV zone and is approx. 60 °C after heating via the PV zone.



Note: In case of prolonged operation without removing the heated storage tank contents, it is necessary to switch off the power supply to the water heater. Setting the rotary knob to a position below "OPTIMUM" does not reduce the water temperature any further, as the temperature for controlling the PV zone (heating element middle and bottom) is fixed (about 60 °C). Due to natural convection, the storage tank also heats up in the upper area (24h comfort zone) when the heating elements in the PV zone are activated.



Neither the thermostat nor any other parts of the control panel are load-bearing parts that could be used for any handling with the water heater.

Settings of the rotary knob:

- **MAX:** Upper limit of the temperature range (about 80 °C).



- **OPTIMUM:** Optimum temperature in normal operation (approx. 55 °C).



- **PV:** Ideal temperature in PV operation (about 45 °C).



- ***:** Frost protection temperature (about 8 °C).
- **MIN:** Lower limit of the temperature range (about 5 °C).



11.1 Hot water pouring rates

The following diagrams show the maximum possible hot water withdrawal at 38 °C with different settings of the comfort range thermostat.

The graph on the left side (entire storage tank) refers to a completely charged storage tank (e.g., in the evening after PV charging).

The right diagram (comfort zone only) refers to the situation when only the comfort zone is available (e.g., at night).

Entire storage tank

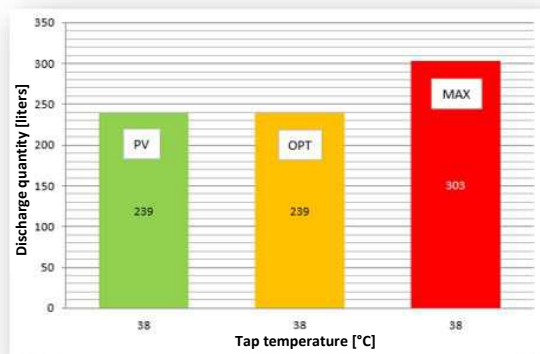

Comfort zone only

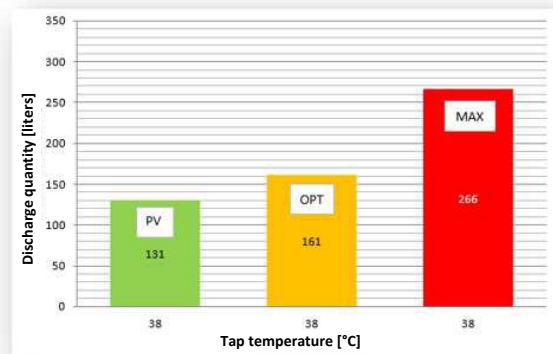

Hot water demand with 38 °C:

Full bath approx. 150 liters, shower bath approx. 40 liters.

Standard value, calculation with cold water temperature 14 °C.

12 Pipeline network to the tapping points

The pipe network must be designed in accordance with applicable international and related local laws, standards, codes and regulations, especially with regard to legionella prophylaxis and pipe insulation.

We recommend certified tapping fittings and dimensionally stable connection pipework (e.g., aluminium composite pipe or stainless-steel pipes) in the sanitary installation to avoid pressure surges in the installation system. In addition, we recommend the installation of pressure-damping fittings for high or variable house connection supply pressures.

The system operator or the professionals working on site are advised of the danger of scalding with hot water.

The system operator must ensure that persons who have not been instructed in the use of the equipment cannot be endangered by scalding with hot water.

Units with electrically operated built-in heaters are equipped with a safety temperature limiter that switches off further heating of the unit at a temperature of approx. 90°C (in accordance with applicable international and related local laws, codes and regulations). Therefore, the selection of the connection components (connection pipes, circulation, safety valve combination, etc.) must be made in such a way that the connection components can withstand temperatures of approx. 90 °C in the event of a malfunction of the temperature controller and that any possible consequences of damage are avoided. Assembly and installation may only be carried out by authorised professionals.

13 Potential equalisation

The potential equalisation is done via the connection cable. In addition, it is possible to connect an earthing in the area of the wall support.

14 First commissioning

The first commissioning and heating must be supervised by a specialist. The storage tank must be filled with water before the first commissioning and connection to the electronic network of the system. During the first filling, the outlet valve on the fitting must be opened. The hot water pipe storage tank is completely filled when water runs out of the outlet pipe of the fitting without any bubbles. All connections, including those that were sealed at the factory, must be checked for leaks during commissioning. As described in chapter 8 *Domestic hot water side connection (pressure-resistant)*, the safety group and the valves between the cold water inlet and the hot water tank must be checked for function. After checking the electrical fuses (circuit breaker), turn the thermostat knob to the desired temperature setting and check for correct temperature cut-off. After heating up, the set temperature and the actual temperature of the water drawn off should be approximately the same (after subtraction of the visual hysteresis and the line losses). If the water in the storage tank is heated, its volume changes. During the heating process, the expansion water produced in the inner boiler must drip out of the safety valve. This dripping is functional and must not be prevented by tightening the valves more. The automatic shutdown of the system must be checked.



WARNING! The hot water drain pipe as well as parts of the safety fitting and the hot water supply pipe can become hot! Danger of burns!

14.1 Procedure for commissioning the water heater

1. Check the water pipe and electrical installation. Check the correct installation of the operating and safety thermostat sensors. The sensors must be inserted into the immersion sleeve as far as they will go. Do not change the order of the operating and safety thermostats.
2. Open the hot water valve on the mixer tap.
3. Open the valve at the cold-water inlet to the water heater.
4. As soon as the water flows out of the hot water valve unclogged, the filling and coiling of the water heater is complete and the valve can be closed.
5. If leaks occur (flange cover), we recommend tightening the screws on the flange cover.
6. Screw on the cover of the electrical installation.
7. Switch on the power supply and activate the PV zone.
8. Document the commissioning.

15 Decommissioning, draining

If the storage tank is put out of operation for a longer period of time or is not used, all poles of the storage tank must be disconnected from the electrical supply network in case of electrical heating – switch off the electrical supply line switch or circuit breaker.

In rooms where there is a risk of frost, the water heater must be drained before the start of the cold season if the unit is to remain out of operation for several days. The domestic hot water is drained after closing the shut-off valve in the cold water supply line via the drain valve of the safety valve combination with simultaneous opening of all hot water valves of the connected utility fittings. Partial draining is also possible via the safety valve into the expansion water funnel (drip catcher). To do this, turn the safety valve to the "Check" position.



WARNING: Hot water may escape during draining!

If there is a risk of frost, it should also be noted that not only the water in the water heater and in the hot water pipes can freeze, but also in all cold water supply pipes to the service fittings and to the unit itself. It is therefore advisable to drain all water-carrying fittings and pipes back to the frost-proof part of the domestic water system (domestic water connection).

If the storage tank is put back into operation, it is essential to ensure that it is filled with water and that water comes out of the fittings without any bubbles!

16 Control, maintenance, care

1. During heating, the expansion water must visibly drip from the drain of the safety valve. At full heating, the amount of expansion water is approx. 4 % of the nominal storage tank capacity. The function of the safety valve must be checked regularly. When lifting or turning the safety valve check knob to the "Check" position, the water must flow unhindered from the safety valve body into the drain funnel.



WARNING! The cold water inlet and parts of the storage connection set may become hot.

If the storage tank is not heated or hot water is not drawn off, no water should drip from the safety valve. If this is the case, either the water pipe pressure is more than the permitted value or the safety valve is defective.

2. If the water has a high lime content, the scale in the inner tank and the free lime deposits must be removed by a specialist after one to two years of operation. Repeated heating of water causes scale to settle on the tank walls and especially on the flange cover. The extent of these deposits depends on the water hardness, the water temperature and the respective hot water consumption. Cleaning is done through the flange opening – dismantle the flange cover, clean the tank, use a new gasket when mounting the flange. The inside of the hot water tank has a special enamel coating that must not come into contact with the cleaning agent used to remove the scale – do not use descaling pumps when working. Remove the limescale deposits with a piece of wood, then vacuum or wipe with a cloth. The screws of the flange cover must be tightened crosswise with a tightening torque of $50 \text{ Nm} \pm 5 \text{ Nm}$. Then rinse the appliance thoroughly and observe the heating process as for the first start-up.
3. Do not use abrasive cleaning agents or paint thinners (e.g., nitro, trichlor, etc.) to clean the outer parts of the unit or the base. The best method is to clean the unit with a damp cloth and a few drops of a liquid household cleaner.
4. Protective anode: the life of the anode is calculated at five years of operation; however, this can vary greatly depending on the water hardness at the place of use and the chemical composition of the water. We therefore recommend checking the protective anode after every two years of operation.

Due to the insulated installation of the magnesium anode in the storage water heater (connection between anode and storage tank by an accessible cable outside the storage tank), this check can be carried out with the aid of an anode tester without interrupting operation and without opening the storage tank.

If the measurement shows that the anode is used up or inactive due to deposits, it must be replaced. The replacement of anodes must be entrusted to a company that performs these services. When draining the water from the hot water tank, the valve of the hot water mixer must be open so that there is no negative pressure in the inner tank that would prevent the water from draining off completely.

The flange seal must be renewed after each opening!

5. Spare parts for regular maintenance: Protective anode, flange seal.

17 Most common dysfunctions and their causes

| Control | Control lights | Solution |
|---|----------------|--|
| The water is cold. | RED light on | <ul style="list-style-type: none"> On the radiator has been set too low a temperature and the PV zone is not activated. |
| The water is cold. | Lights off | <ul style="list-style-type: none"> No supply voltage. Defective thermostat. Safety thermostat is switched off – this was probably caused by the defective operating thermostat. |
| Hot water quantity is low. | Lights on | <ul style="list-style-type: none"> Parts of the heating element are defective. PV zone thermostats are defective. |
| Water temperature does not correspond to the temperature set on the controller. | | <ul style="list-style-type: none"> Defective thermostat. |
| Water drips constantly from the safety valve. | Lights off | <ul style="list-style-type: none"> High inlet pressure. Damaged safety valve. |



Do not attempt to fix the fault yourself. Please contact either a specialist workshop or the customer service. The specialist can usually rectify such a fault in no time at all. When making the repair agreement, please state the type designation and production number on the rating plate of your water heater.

18 Warranty, guarantee and product liability

The NORD EcoBoiler 160 suspended hot water tanks are the result of careful planning and manufacturing. We only use high-quality materials and subject our products to constant quality controls. Should there nevertheless be a reason for complaint, please note the following warranty conditions.

18.1 Warranty

The warranty is provided in accordance with applicable international and related local laws, codes and regulations.

- 10 years on the inner vessel

only if the service inspections are performed at least once a year and the anodes are replaced, the conditions of the installation instructions in point 7 are observed and the reasons for exclusion from the warranty are not caused, see point 18.3 of the installation instructions.*

- 5 years warranty on all other materials

only if the service inspections are performed at least once a year and the anodes are replaced, the conditions of the installation instructions in point 7 are observed and the reasons for exclusion from the warranty are not caused, see point 18.3 of the installation instructions.*

- 2 years legal warranty (material + labour)

mandatory warranty, including on-site replacement of technology by an authorized technician

* Material warranties include replacement of defective parts, including delivery to the site, excluding labor by the technician to replace the defective part.

18.2 Provision of warranty

A prerequisite for the provision of warranty services by the manufacturer is the presentation of the paid invoice for the purchase of the appliance for which the warranty service is claimed, whereby the identity of the appliance with regard to type and serial number must be evident from the invoice and must be presented by the claimant. The General Terms and Conditions as well as the sales and delivery conditions of the manufacturer shall apply exclusively.

Manufacturer reserve the right to decide whether a defective part is to be replaced or repaired, or whether a defective unit is to be exchanged for a defect-free unit of equal value. The guarantee period is neither renewed nor extended by the submission of guarantee and warranty claims, service and maintenance work, but is still valid from the day of commissioning.

The assumption of costs for repairs carried out by third parties presupposes that the producer has been requested to fix the defect and has not fulfilled its obligation to replace or repair the product or has not done so within a reasonable period of time.

Claims beyond the scope of the warranty, such as in particular claims for damages and consequential damages, are excluded insofar as they are legally permissible. Proportionate working hours for repairs as well as the costs of restoring the system to its original condition must be paid in full by the buyer. The costs for necessary changes to the structural conditions (e.g., doors and passages that are too narrow, planking) are not subject to the promised guarantee and warranty and are therefore rejected by the producer. In accordance with this guarantee declaration, the warranty only covers the repair or replacement of the appliance or component.

18.3 Reasons for exclusion

The following do not entitle the user to claim under the warranty and guarantee:

Improper transport, normal wear and tear, intentional and/or negligent damage, use of force of any kind, mechanical damage or damage due to frost or even a single exceeding of the operating pressure specified on the rating plate. Use of a connection set that does not comply in accordance with applicable international and related local laws, codes and regulations or non-functional storage tank connection set as well as unsuitable and non-functional service fittings. Breakage of glass and plastic parts, possible colour differences, damage due to improper use, in particular due to non-observance of the assembly and operating instructions (operating and installation instructions), damage due to external influence, connection to incorrect voltage, corrosion damage as a result of aggressive water not suitable for drinking water in accordance with applicable international and related local laws, codes and regulations, natural limestone formation, water shortage, fire, flood, lightning strike, overvoltage, power failure or other force majeure, use of non-original and non-company components such as heating elements, thermostats, etc., foreign body ingress or electrochemical influences, non-observance of the planning documents, lack of or improper cleaning and operation, as well as such deviations from the standard that only slightly reduce the value or functionality of the unit.

In principle, all applicable international and related local laws, codes and regulations must also be complied with in the event of any other loss of claims against manufacturer.

In the event of third-party interventions without our express order, even if these are carried out by a licensed installer, any warranty, guarantee and/or compensation claim shall lapse.

18.4 Product liability

In order to obtain claims in accordance with applicable international and related local laws, codes and regulations, it should be noted:

Possible claims under the title of product liability for the settlement of damages caused by the defect of a product (e.g., a person is injured in the body, his health is damaged or a physical object different from the product is damaged) are only justified if all prescribed measures and necessities, which are necessary for the fault-free and standard-compliant operation of the device, have been fulfilled. Damage due to improper use must be avoided. These requirements are to be derived from the fact that if all regulations (standards, installation and operating instructions, general guidelines, etc.) had been complied with, the defect in the unit or product causing the secondary damage would not have occurred. Furthermore, it is indispensable that the necessary documents, such as the designation and manufacturing number of the storage device, the invoice of the seller and the executing concessionaire as well as a description of the malfunction for the laboratory examination of the claimed storage device (absolutely necessary, as an expert will examine the storage device and analyse the cause of the defect), are made available to manufacturer for settlement. In order to be able to exclude a mix-up of the storage unit during transport, the storage unit must be provided with a clearly legible marking (preferably with the address and signature of the end customer). A corresponding picture documentation of the extent of the damage, the installation (cold water supply line, hot water outlet, safety fittings, expansion vessel if applicable), as well as the location of the defect of the storage tank is required. Furthermore, manufacturer expressly reserves the right to demand that the buyer provide the documents and devices or device parts necessary for clarification. A prerequisite for the provision of services under the title of product liability is that it is entirely up to the injured party to prove that the damage was caused by the product of manufacturer. Until the entire facts and circumstances have been clarified and the causal cause of the defect has been determined, any possible fault on the part of manufacturer is decidedly excluded. Failure to follow the operating and assembly instructions, the connection instructions and the relevant standards is to be considered negligent and leads to an exclusion of liability in the area of compensation for damages.

19 Notes on transport and storage

The unit must be transported and stored in a dry environment, protected from the weather, in a temperature range from -15 °C to +50 °C. When loading and unloading, be sure to follow the instructions on the packaging.

20 Disposal

A disposal fee has already been paid for the packaging in which the water heater was delivered for the return and recycling of the packaging material.

Hand in the packaging of the water heater at the collection point designated by your municipality for landfill/disposal of waste. The used and unusable product must be dismantled after the end of operation and delivered to the waste recycling centre (collection yard); otherwise, please contact the manufacturer.

The illustrations and data are non-binding and may be changed without comment in the interest of technical improvements.

Misprints and technical changes reserved. Status 2023-5.



NORD HT AS
Plattformvegen 2, 4056 Tananger, Norway

www.nord-solution.com